 <p data-bbox="315 579 688 642"> <b>exalt</b> THE CREATOR      <b>enrich</b> THE BELIEVER      <b>enlighten</b> THE SEEKER  EMBRACING the VISUAL ARTS MINISTRY </p>	<h2 data-bbox="935 176 1305 226">CALL FOR ART</h2> <h3 data-bbox="863 302 1373 516">FOURTH ANNUAL AWARDED COMPETITION AT CHARIS GALLERY</h3> <h3 data-bbox="883 592 1357 634">MAY 17 – JULY 19, 2020</h3>
--	---

## CASH AWARDS

**BEST of Show**  
\$200

**FIRST Place**  
\$150

**SECOND Place**  
\$100

**THIRD Place**  
\$75

## DETAILS

Exhibit Dates	May 17 – July 19, 2020
Entry Deadline	April 16, 2020 (Thursday)
Response to Entrants	By April 30, 2020 (Thursday)
Delivery of Accepted Works	May 14, 2020 (Thursday) 10-11 am
Final Judging	May 14, 2020 (Thursday)
Opening Reception & Presentation of Awards. Friends and Family are welcome!	May 17, 2020 (Sunday) 12-1 pm Meet the artists and celebrate with the winners!
End of Show	July 19, 2020 (Sunday)
Pick up Work	July 20, 2020 (Monday) 10-12 noon

- **INSTRUCTIONS: Download and print the attached PDF.**
- Complete the entry form, write your check and bring both to the Worship Arts Office, or mail it to Charis Gallery at Roswell UMC, 814 Mimosa Blvd., Roswell GA 30075.
- Save your images at 300 dpi, .jpg or .png.
- Title the image like this: your **last-name-1of3-title of entry.jpg**.  
(example: **moore-1of3-hope-I-win.png**)
- Email them to [charisgallery@rumc.com](mailto:charisgallery@rumc.com).
- Contact Ann Moore at 770.261.1719 or [amoore@rumc.com](mailto:amoore@rumc.com) for any questions. We are here to help!

## ENTRY REQUIREMENTS

All two- and three- dimensional art mediums will be considered. Sorry, no student work. Participants must be 18 years and older.

### Entry Fees:

- \$20 (nonrefundable) entry fee.
- Submit up to three entries.
- Pay by check.

### Make certain each submission:

1. is your original artwork
2. was created within the last three years
3. does not contain content deemed inappropriate for a church setting
4. 2-D: size - 48" maximum in any direction, including frame
5. 3-D: no larger than 14.5" wide by 27" high x 13" deep, for glass encasement.

### If accepted, your entry must:

1. be properly framed, ready for hanging, with hardware and wire attached along with stabilizing screw eyes or horseshoe staples 2" from the top of frame \*
2. have all exposed edges of gallery-wrapped canvases finished, two-to-three inches deep with no exposed staples
3. remain in the gallery until the exhibit has officially ended

### \* IMPORTANT!

Install screw eyes or heavy-duty staples on the back of your frame, two inches (2") down from top left and right edges (see diagram below). This extra step ensures your work will hang vertically, and not lean away from the wall. If you forget, the hanging committee will either (a) not hang your work, or (b) with your permission\*\*, install horseshoe staples on the back of your work, but cannot be held responsible for accidental damage if it occurs.

Metal frames are permitted and will be prepared to hang with a different method. The committee will prepare them for hanging.

\*\*permission to apply staples will be approved on the artist sign-in sheet when accepted work is checked in for hanging.

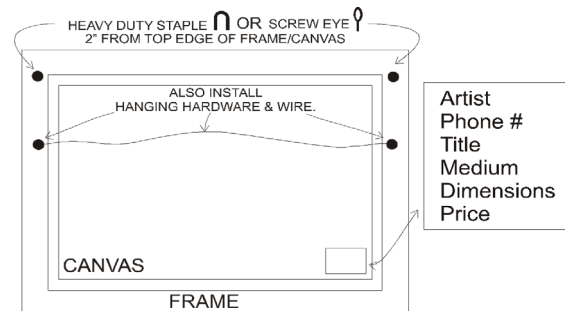

- **INSTRUCTIONS: Download and print the attached PDF.**
- Complete the entry form, write your check and bring both to the Worship Arts Office, or mail them to Charis Gallery at Roswell UMC, 814 Mimosa Blvd., Roswell GA 30075.
- Save your images at 300 dpi, .jpg or .png.
- Title the image like this: your **last-name-1of3-title of entry.jpg**.  
(example: **moore-1of3-hope-I-win.png**)
- Email them to [charisgallery@rumc.com](mailto:charisgallery@rumc.com).
- Contact Ann Moore at 770.261.1719 or [amoore@rumc.com](mailto:amoore@rumc.com) for any questions. We are here to help!!

# CHARIS GALLERY ENTRY FORM

Name First		Last		
Phone		Email		
Address		City	State	Zip
How many pieces are you entering?	1	2	3	How did you learn about this upcoming exhibit?

## ENTRY 1

Title		Medium		
<b>2-Dimensional</b> ____ W x ____ H (Including Frame)*	<b>3-D Dimensional</b> ____ W x ____ H x ____ D	<b>Is this work for sale?</b>	<b>Yes \$</b>	<b>No</b> Not Available for Purchase
<p><b>Your thoughts about the work.</b> Although not a requirement, if there is a spiritual connection with your entry, we would love to hear about it! These comments will be printed on a card and placed beside your work. Write on the back of your entry form, or feel free to attach your explanation if you need more room.</p>				

## ENTRY 2

Title		Medium		
<b>2-Dimensional</b> ____ W x ____ H (Including Frame)*	<b>3-D Dimensional</b> ____ W x ____ H x ____ D	<b>Is this work for sale?</b>	<b>Yes \$</b>	<b>No</b> Not Available for Purchase
<p><b>Your thoughts about the work.</b> Although not a requirement, if there is a spiritual connection with your entry, we would love to hear about it! These comments will be printed on a card and placed beside your work. Write on the back of your entry form, or feel free to attach your explanation if you need more room.</p>				

## ENTRY 3

Title		Medium		
<b>2-Dimensional</b> ____ W x ____ H (Including Frame)*	<b>3-D Dimensional</b> ____ W x ____ H x ____ D	<b>Is this work for sale?</b>	<b>Yes \$</b>	<b>No</b> Not Available for Purchase
<p><b>Your thoughts about the work.</b> Although not a requirement, if there is a spiritual connection with your entry, we would love to hear about it! These comments will be printed on a card and placed beside your work. Write on the back of your entry form, or feel free to attach your explanation if you need more room.</p>				

By signing and submitting this form, I understand that exhibiting my art at Charis Gallery is at my own risk. Charis Gallery and Roswell United Methodist Church will do everything possible to ensure its safety.

Artist's Signature and Date